

PLATFORM SCALES WITH PLASTIC HEAD

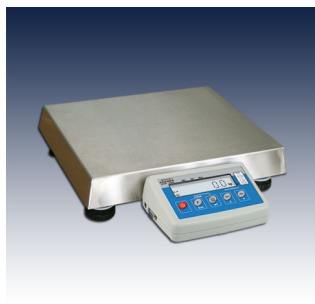
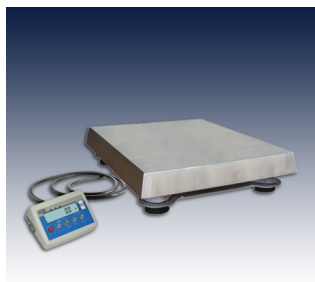
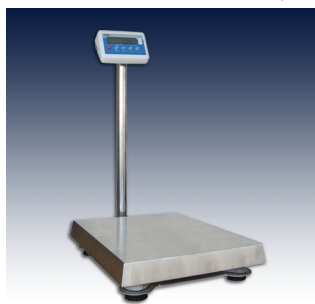

Ramp scales are designed for direct trading and in those applications, where fast and precise determination of net mass is necessary.

They are equipped with measuring indicator series PUE C31 with backlit LCD display installed on:

- a pillar with possibility of adjusting the angle (WTC version);
- a cable (version WTC/K);
- at the platform (version WTC/R).

Scale is manufactured in mild steel, stainless steel weighing pan. Scales are equipped with two power supply options: mains or batteries (6 x AA).



Counting pieces



Checkweighing



Summing function

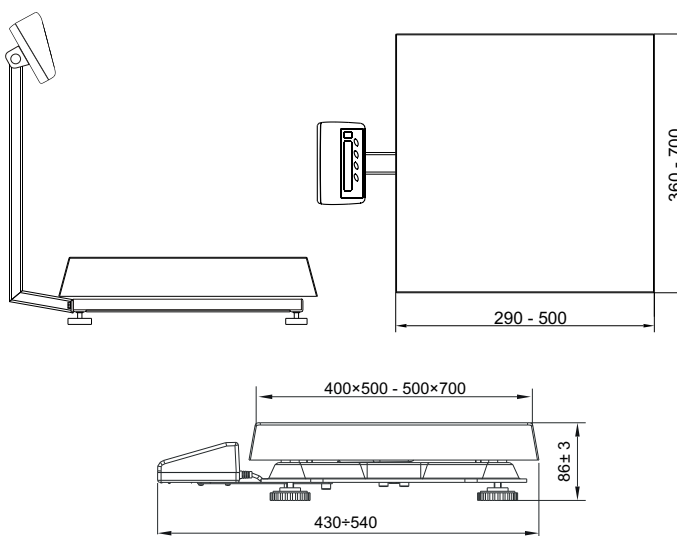

Construction of scale WTC/C

Technical data:

	WTC 6 C1	WTC 15 C1	WTC 30 C1		WTC 60 C2	WTC 150 C2	WTC 300 C2	WTC 150 C3	WTC 300 C3	
	WTC 6 C1/K	WTC 15 C1/K	WTC 30 C1/K		WTC 60 C2/K	WTC150 C2/K	WTC 300 C2/K	WTC 150 C3/K	WTC 300 C3/K	
	WTC 3 C1/R	WTC 6 C1/R	WTC 15 C1/R	WTC 30 C1/R	WTC 30 C2/R	WTC 60 C2/R	WTC150 C2/R			
Max capacity	3 kg	6 kg	15 kg	30 kg	30 kg	60 kg	150 kg	300 kg	150 kg	300 kg
Readability	1 g	2 g	3 g	10 g	10 g	20 g	50 g	100 g	50 g	100 g
Tare range	-3 kg	-6 kg	-15 kg	-30 kg	-30 kg	-60 kg	-150 kg	-300 kg	-150 kg	-300 kg
Pan size	290 × 360 mm	290 × 360 mm	290 × 360 mm	290 × 360 mm	400 × 500 mm	400 × 500 mm	400 × 500 mm	400 × 500 mm	500 × 700 mm	500 × 700 mm
Working temperature	-10° - +40 °C									
Output signal	RS 232									
IP rating	IP 65 construction, IP 54 indicator									
Power supply	230V 50Hz AC / 11V AC and 6 x AA									
Display	LCD (backlit)									

Additional equipment:

RACK FOR HEAD

LCD ADDITIONAL DISPLAY

"KAFKA" THERMAL PRINTER

NEEDLE PRINTER "EPSON"

TABLE FOR SCALE

EXTERNAL RECHARGEABLE BATTERY PACK

COMPUTER SOFTWARE: PW-WIN 2005

COMPUTER SOFTWARE: RAD-KEY 2000

COMPUTER SOFTWARE: REC-FS 2000

COMPUTER SOFTWARE: LS-FS 2000

RS 232/RS 485 CONVERTER

EXTERNAL POWER OUTPUT

Zakład Mechaniki Precyzyjnej RADWAG

26-600 Radom, Bracka Street 28 POLAND
 Phone: +48 48 3848800 Fax: +48 48 3850010
 Sales department: +48 48 3668006
 www.radwag.com e-mail: export@radwag.com

DISTRIBUTOR: