

OVERHEAD TRACK SCALES

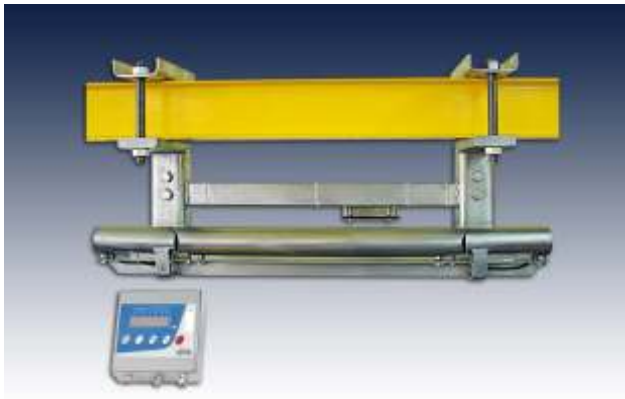

Designed for weighing loads which move on tracks of scales. Scale can cooperate with device for evaluating meat content. LCD backlit indicator installed on a wire.

Overhead scales are manufactured either in galvanized and in stainless steel version, as dual range weighing instruments. They are equipped with stainless steel backlit LCD measuring indicator PUE C/31H.

Special software allows for cooperation with a device for meat content evaluation.

- Counting pieces
- Checkweighing
- Summing function
- 2 years warranty period

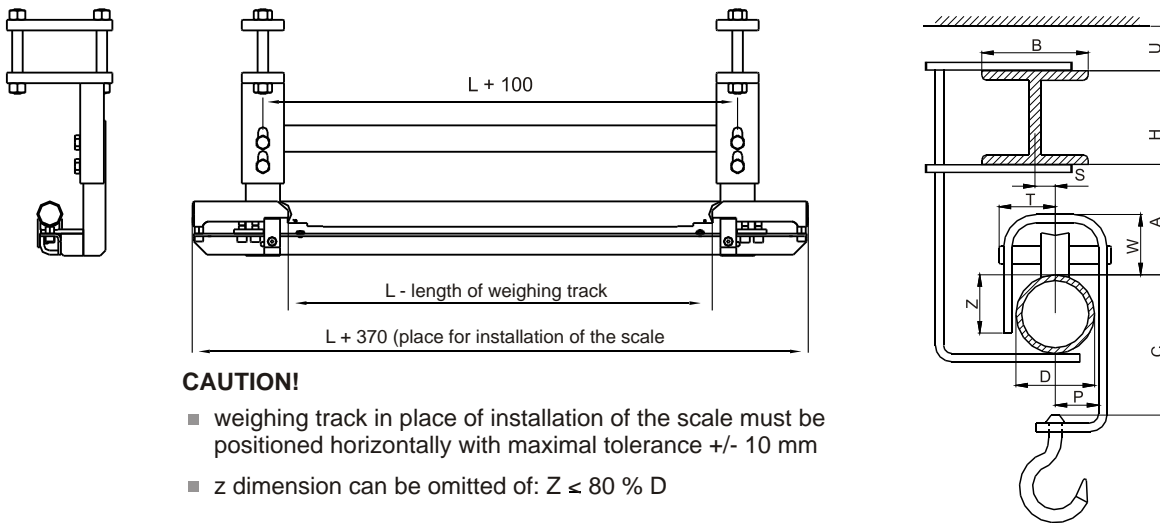

Technical data:

	WPT/2K 300/600	WPT/2K 300/600H
Max capacity	300/600 kg	300/600 kg
Readability	0,1/0,2 kg	0,1/0,2 kg
Tare range	-600 kg	-600 kg
Scale construction	galvanized	stainless steel
Track length		max. 800 mm
Working temperature		-10° - +40 °C
Output signal		RS 232
Power supply		230V, 50Hz
Display		LCD (backlit)

Additional equipment:

- RACK FOR HEAD
- LCD DISPLAY
- LARGE SIZE LCD DISPLAY
- "KAFKA" THERMAL PRINTER
- NEEDLE PRINTER "EPSON"
- COMPUTER SOFTWARE: PW-WIN 2005
- COMPUTER SOFTWARE: RAD-KEY 2000
- RS 232/RS 485 CONVERTER
- EXTERNAL POWER OUTPUT

Zakład Mechaniki Precyzyjnej RADWAG

26-600 Radom, Bracka Street 28 POLAND
 Phone: +48 48 3848800 Fax: +48 48 3850010
 Sales department: +48 48 3668006
 www.radwag.com e-mail: export@radwag.com

DISTRIBUTOR: