

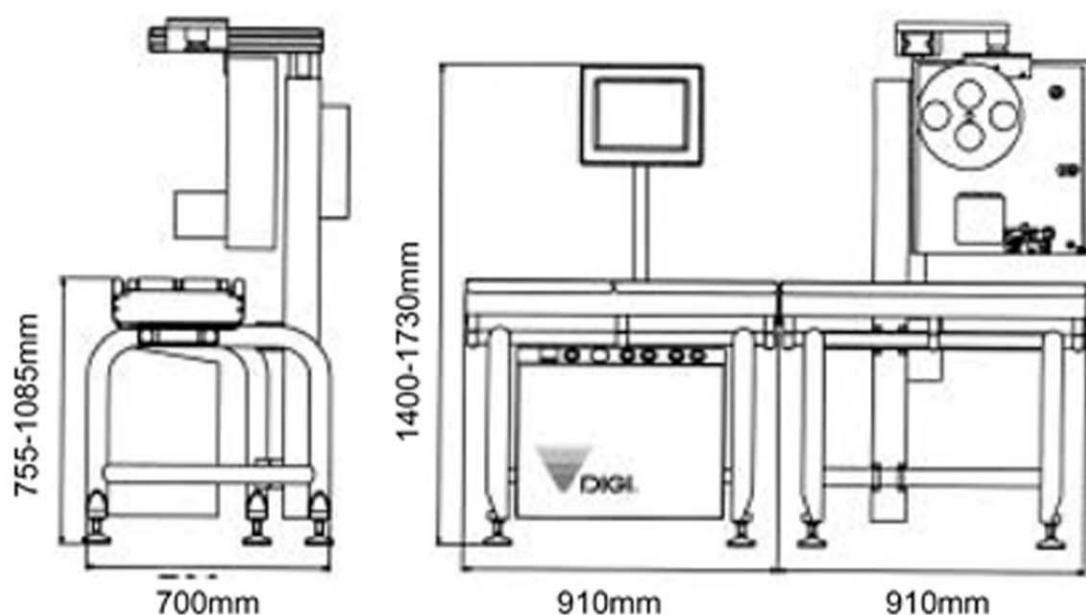

HI-700

DIGI Europe's range of weighing and labelling systems are used extensively within the world's food industry.

We realise the importance of quality through innovation and employ the latest technology to continually expand and upgrade our production range.



CW-700



700 series

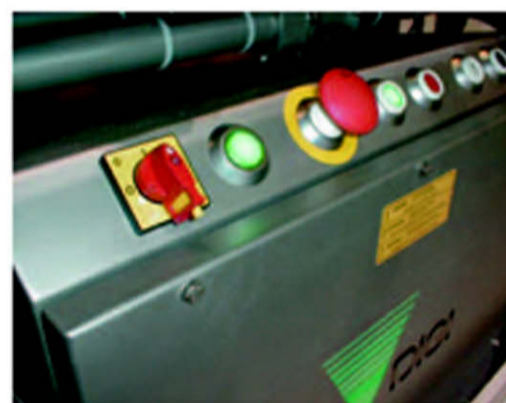
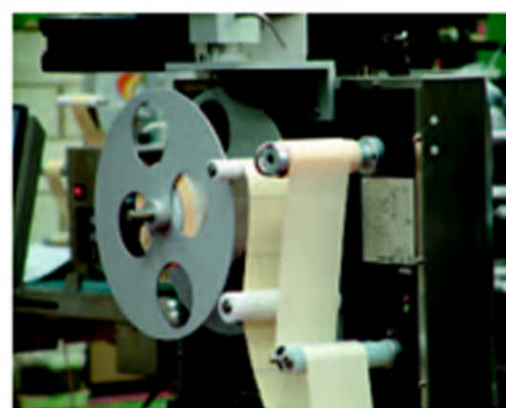

Capacity/Interval	Up to 6 kg x minimum 1 g interval
Print Method	108.4 mm at 12 dots/mm Other Options to be announced
Pack size	80-300 mm (3.15-11.81") (L) 40-250 mm (1.57-9.84") (W) 180 mm maximum (7.09") (H)
Label size	Min. 30 mm (1.18") (W) x 28 mm (1.10") (H) Max. 120 mm (4.72") (W) x 150 mm (6") (H)
Application system	Airbox, stamp, concave or touch
Label Format	Limited by size of hard disk
Memory Items	Limited by size of hard disk
Preset Data	PLU code, price, pack quantity, pack date, sell by date, time, shop name, commodity name, traceability etc
Pack Speed	Up to 150 packs per minute
Label Roll	Roll diameter 300 mm (11.8") Core diameter 76 mm (3.0") outside or inside wound
Power	220-240V (115V option) 50/60 Hz AC single phase

As part of our policy of continued product development, DIGI reserve the right to alter the specification and design without prior notice - E&OE.

New Brunswick International, Inc.

76 Veronica Avenue
Somerset, NJ 08873
Phone - (732) 828-3633
Fax - (732) 828-4884
www.nbidigi.com

